



FAIRBANKS - MORSE

FM H12-44 PHASE 1 (1950-1953)

WHEELS OF TIME N-SCALE

LOCOMOTIVE DIY KITS

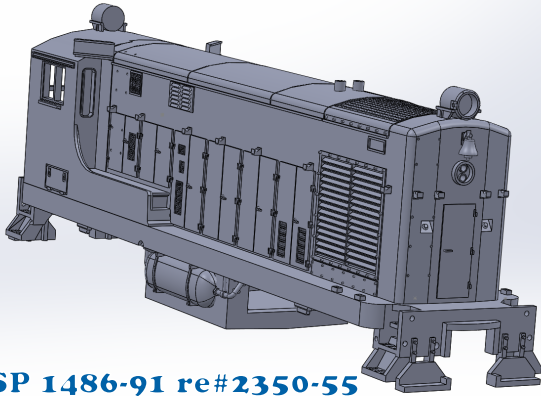

SP 1486-91 re#2350-55

Pyle-National ash can warning lights, number board, battery box, twin hood vents, no roof overhang

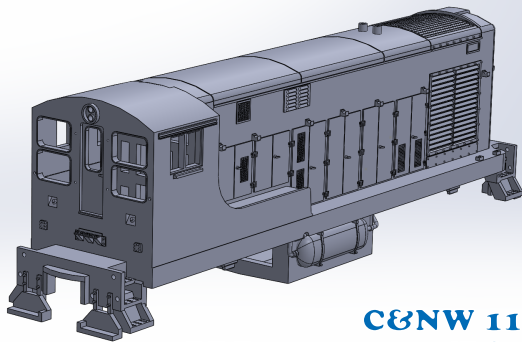

**C&NW 1110-1113;
PRR 8711-8723 (PC 8327-39)**

Low mounted headlight, low door, no front mounted bell, no roof overhang, twin hood vents

Wheels of Time is proud to announce early FM H12-44 (Phase 1) for five railroad specific variations. Early H12-44 rode on "long frame" - a perfect match using Atlas' VO-1000 switcher mechanism.

DIY Kit: Locomotive shell w/walkways, realistic fuel-air tanks, laser cut cab windows.

Requires Atlas' VO-1000 switcher mechanism, 15" grab irons, .010" diameter rod, paint & decal, assembly.



ATSF 507-530

High headlight & door, no front mounted bell, roof overhang, twin hood vents, tall exhaust stacks

**MILWAUKEE RD 715-739
Weyerhaeuser Timber Co 1**

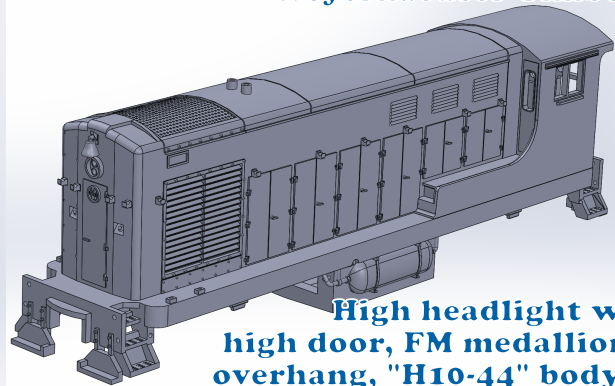

High headlight w/ bell, high door, FM medallion, roof overhang, "H10-44" body vents

**B&O 310-319 re#9710-9719
NYC 9111-9120 (PC 8303-09)
K&I Terminal 60-64**

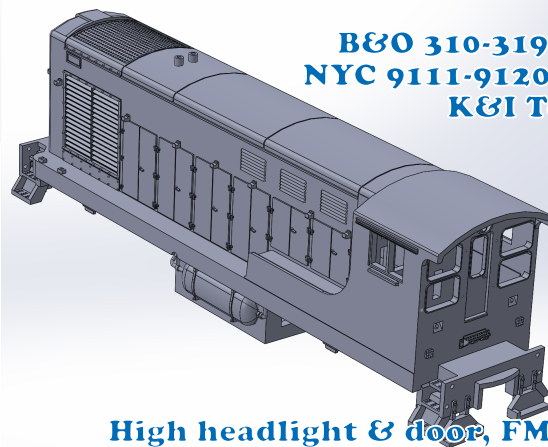

High headlight & door, FM medallion, no front mounted bell, roof overhang, "H10-44" body vents

See www.wheelsotime.com for more details.



**Pre-orders due
July 20, 2023.
ETA Sept-Oct 2023**



FAIRBANKS - MORSE

FM H12-44 PHASE 1 (1950-1953)

WHEELS OF TIME N-SCALE

LOCOMOTIVE DIY KITS



Fairbanks-Morse (FM) made it's start as a scale weighing manufacturer in 1823. They diversified into pumps, water standpipes, track cars, and electric motors. In 1930, they built their highly successful opposed-piston diesel engine for the U.S. Navy submarine service. This high power compact design - think two opposing pistons in one cylinder with two crankshafts - became their hallmark design. Their short lived entry into the locomotive business was from 1944 to 1963 which used this engine design. FM 1200 h.p. switcher locomotive was a follow-on from their successful 1000 h.p. switcher H10-44. The first H12-44 customer was the Milwaukee Road as number 1826 (re # 750) in May 1950. These locomotives were durable if well-maintained and lasted into the 1970s.

Phase 1 (a rail fan term only) was produced from 1950 to 1953. They rode on long frame truck wheel base, had the distinct Loewy-styled curve fairing from cab, and with most units having the top of the hood front trim.

Wheels of Time is delighted to produce five railroad-specific variations within Phase 1. They include high or low front hood door, high or low mounted headlight, FM medallion, cab roof overhang, front mounted bell, "H10-44 side hood" vents or twin hood vents, and of course for SP - their Pyle-National ash can warning lights. These variations cover Santa Fe, Baltimore & Ohio, Chicago & North Western, Milwaukee Road, New York Central, Pennsylvania, Southern Pacific, Kentucky & Indiana Terminal, Weyerhaeuser Timber Co. and Penn Central - not a complete roster.

With 3D print technology combined with our digital CAD modeling skills, these early FM H12-44 are now possible to be manufactured. Further, Wheels of Time is grateful to the Golden Gate Museum's availability of their ex-US Army unit - painted in SP colors, so we can measure it.

DIY Kit includes highly detailed and prototype specific locomotive shell with walkways, realistic looking fuel-air tanks, and laser cut cab windows. You will need: Atlas' VO-1000 switcher mechanism, 15" BLMA-Atlas grab drop grab irons, .010" diameter rod such as from Tichy Train Group, glue, primer & paint, decal and your creative energy. Ready for a fun project?

Item / Description / MSRP

80001 Southern Pacific: Pyle National Lights, low door, no hood trim, bell, twin hood vents

80002 Santa Fe: roof overhang, no medallion, twin hood vents, no bell, high door

80003 Milwaukee, Weyerhaeuser: roof overhang, medallion, high mounted headlight & bell, high door, three large vents

80004 C&NW, Pennsylvania, PC: no roof overhang, no bell, low headlight, low front door, twin vents

80005 B&O, KIT, New York Central: roof overhang, three large vents, no medallion, high door and headlight.

MSRP - \$58

See www.wheelsotime.com for more details including prototype photo links.



**Pre-orders due
July 20, 2023.
ETA Sept-Oct 2023**

